

CUSTOM-ENGINEERED

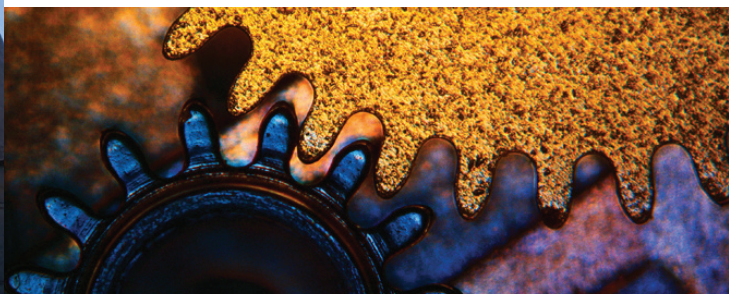

Circular Economizers

- Improve boiler efficiency by 3%–8%
- Typical installed payback of less than one year



APPLICATIONS



Pollution Control-Thermal Oxidizers



Ethanol Production



Pulp and Paper



Petrochemical



Engine and Turbine Exhaust

Custom solutions ranging from 100–1200 hp.

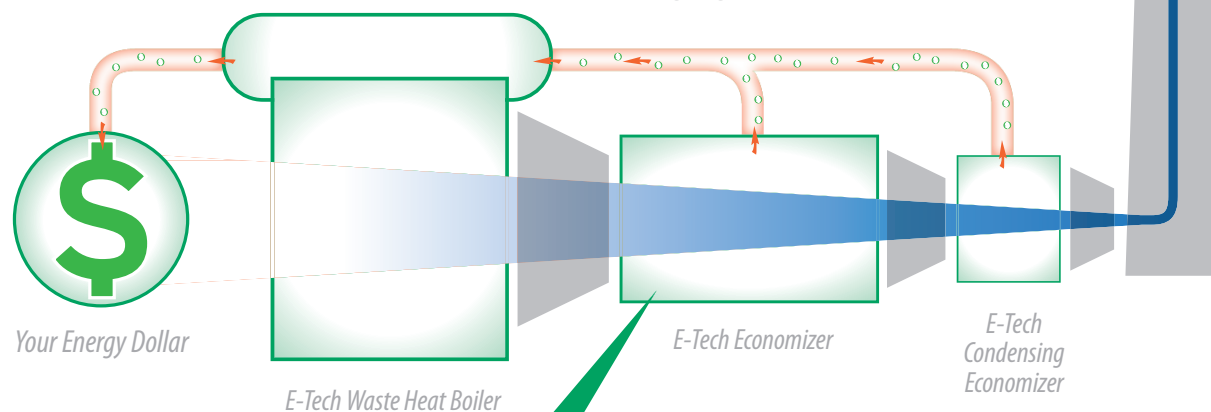

Our custom-designed **circular economizers** provide an excellent option for large capacity boilers. They can be configured to accommodate either horizontal or vertical gas flow and can be precisely matched to your performance, pressure-drop and space requirements.

The cost-effective way to increase boiler efficiency.

Circular Economizer

Our circular economizers preheat boiler feedwater using recaptured heat from flue gases. The typical net result is a 1% increase in boiler efficiency for each 40°F decrease in flue gas temperature.

Circular economizers by E-Tech feature high-frequency solid fins welded to the tube, a design that yields a more durable and easily cleaned unit than one with brazed or fused finning.

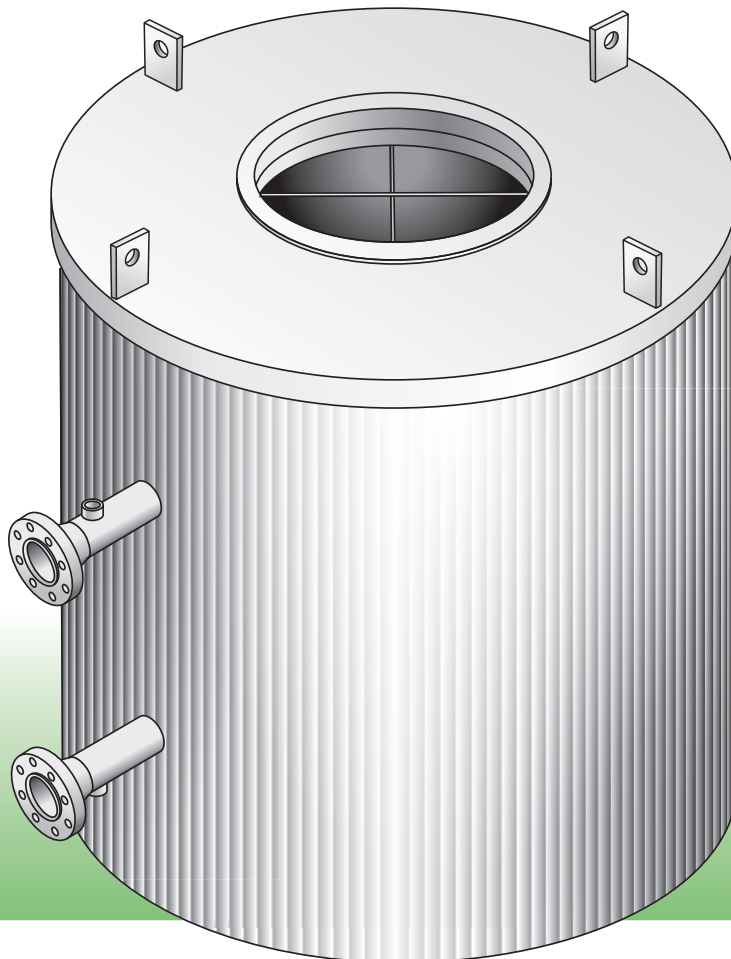

At E-Tech, we've been engineering precise custom solutions for our customers' waste heat recovery needs for more than 30 years, producing literally thousands of designs for virtually every type of application.

To ensure that finished products reflect our exacting standards, we contract with hand-picked,

exclusive subcontractors we know we can rely upon to maintain our exacting specifications and standards throughout manufacturing, inspection and shipment.

This thorough process ensures that whether you purchase a single component or a complete system, your E-Tech waste heat recovery equipment will meet your needs effectively and reliably for years to come.

918-665-1930 | www.e-techinc.com

Our difference is **GREENENGINEERING™**.

E-Tech heat recovery solutions produce efficiencies of up to 95% from your fuel dollar, while reducing pollutants in your exhaust. And we're constantly moving forward with new ideas to serve more industries with greater efficiency. So "green" is what your company saves ... and how it behaves.